



1935 SHELTER SYSTEM

Features and Benefits

- Rapid deployment without aid of ancillary equipment, set-up anywhere
- Lightweight frame, packaging allows shelter to be moved / stowed by two people
- Vertical 6 ft. sidewalls maximize usable square footage
- Sealable vinyl floor maintains environmentally secure shelter (SW-1935)
- Can be configured with roof or walls only for maximum flexibility in deployment
- Interior frame allows access to horizontal support bars capable of holding up to 50 lbs
- Rigid double doors provide a large entryway
- Roof vent caps significantly reduces condensation
- Framework design allows individual replacement of parts
- Flame retardant vinyl is UV resistant for long life, resists mildew and abrasion

Shelter Packages

SH-1935	SW-1935
1 Frame	1 Frame
2 Vent Cap	2 Vent Cap
1 Roof	1 Roof
1 Wall	1 Wall
1 Double Door	2 Double Door
1 Stake Kit	2 Stake Kit
1 Vinyl Repair Kit	1 Vinyl Repair Kit
	1 Floor
	2 Threshold Ramp

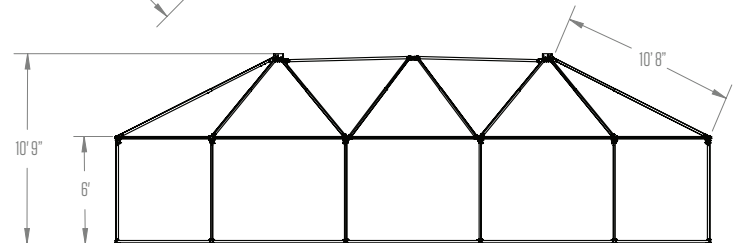
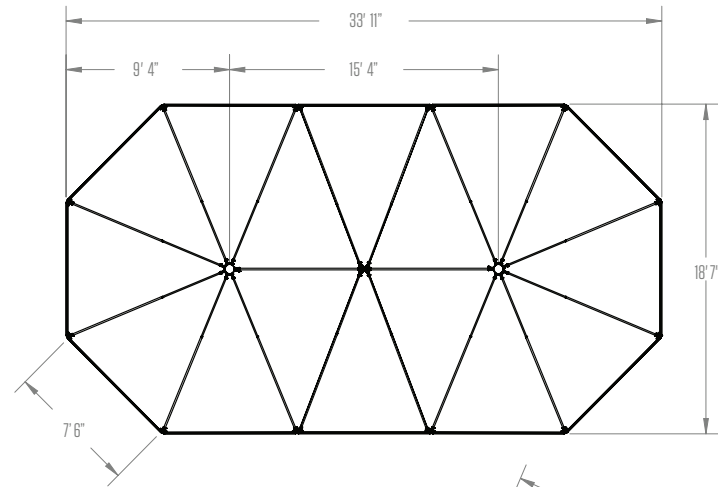

Specifications NSN Pending

Usable Area	18'7" x 33'11"	(5.7 x 10.4 m)
Total Weight	596 lbs	(270 kg)
Time Under Canopy	20 min / 4 personnel	
Total Set-Up Time	35 min / 4 personnel	
Square Footage	570 ft ²	(53m ²)
Cube	3,420 ft ³	(96.84 m ³)
Environment	-40°F - 120°F	(4.4°C to 49°C)
Snow Load	10 lbs / ft ² for 12 hrs	(50 kg / m ² for 12 hrs)
Wind Load	55 mph w/gusts to 65 mph	(89 km/h w/gusts to 105 km / h)
Dimensions		
Footprint	18'7" x 33'11"	(5.7 x 10.4 m)
Sidewall	6'	(1.8m)
Peak	10'10"	(3.3m)
Packaged Dimensions		Weights
Roof	21 x 23 x 14"	(53 x 58.5 x 35.5 cm) 76 lbs (34.4 kg)
Door (2)	26 x 3.5 x 72"	(66 x 9 x 183 cm) 45 lbs (20.4 kg)
Wall	28 x 28 x 14"	(71 x 71 x 35.5 cm) 110 lbs (49.8 kg)
Vinyl Floor	23 x 20 x 14"	(58.5 x 51 x 35.5 cm) 86 lbs (39 kg)
Frame (1)	91 x 16 x 16"	(231 x 40.5 x 40.5 cm) 126 lbs (57 kg)
Frame (2)	91 x 14 x 16"	(231 x 35.5 x 40.5 cm) 108 lbs (49 kg)
Berry Compliant Option	✓	

Recommended Support Systems

Shelter Connecting Systems

Increase the footprint of your shelter system with rigid frame connectors and entryways

Electrical Distribution

Portable power and lighting to sustain your shelter complex

Climate Control

Air heating, cooling, purifying and dehumidifying

Water Distribution

Purification, storage, heating and distribution kits

Hygiene Systems

Field showers and toilet stations

Storage And Transport

Heavy-duty cases and customizable cargo trailers

Digital ID

Your logo or name custom printed on roofs and doors for easy identification

Anchoring Systems

Secure your shelter against high winds

Shelter Accessories

Beds, work stations, tables, seating and food prep



Thirteen 1935s connected by vestibules make up this field hospital.



Shelter billeting featuring Western Shelter bunk beds, air distribution plenum, lighting and wiring harness.